

White Paper

# Tomorrow's Power in the Field

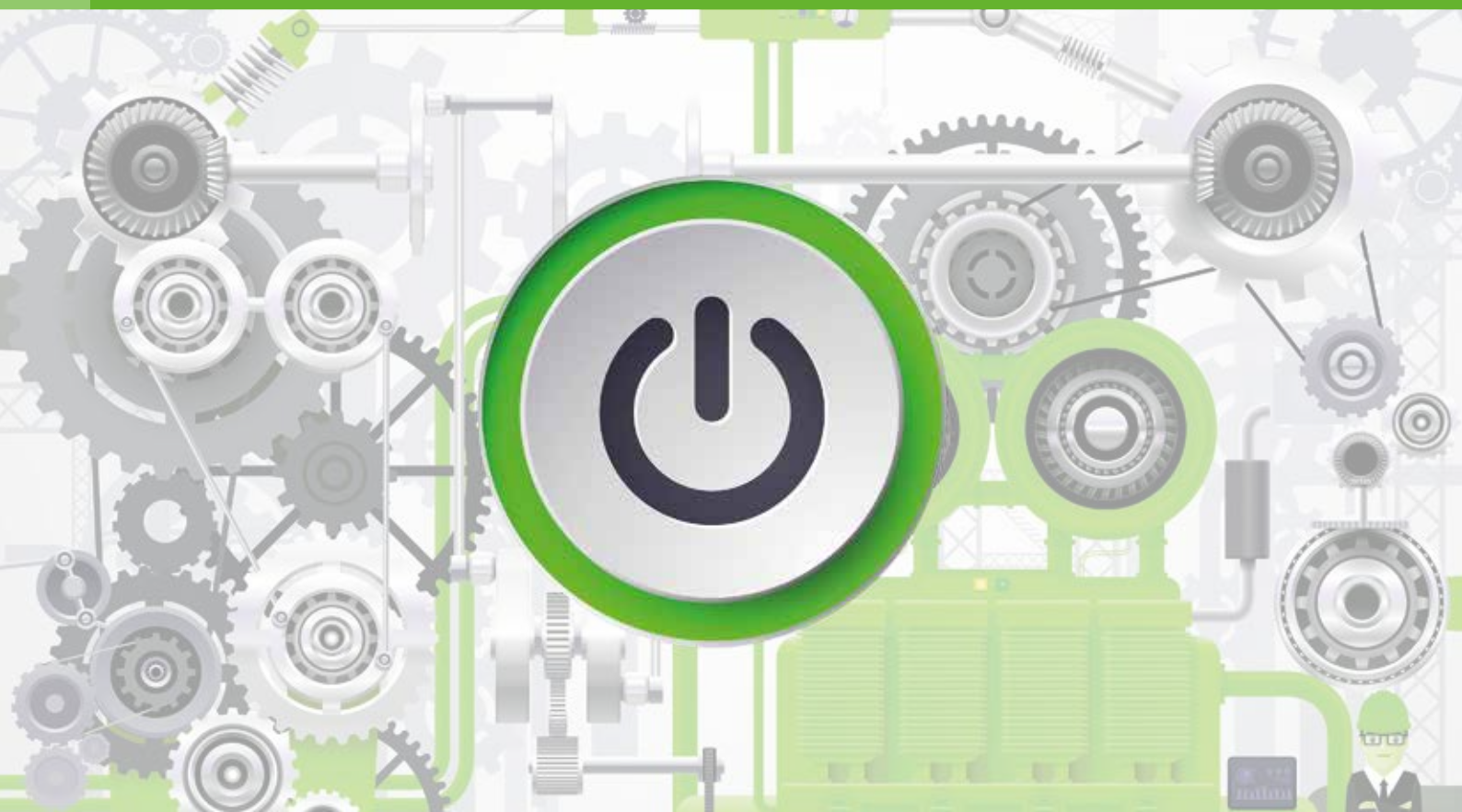

## Tomorrow's Power in the Field

Decentralization plays a key role within digitization in automation technology. True to the zero cabinet philosophy, there is a growing trend towards shifting applications and components out of the traditional control cabinet (IP20) and into the field (IP67) as part of smaller units or machines. The increasing level of automation and need to map digital twins goes hand in hand with growing signal and data density and more compact dimensions. This 'miniaturization' increases power and performance needs.

This white paper provides an overview of important changes in the field, and, for PROFINET applications in particular, the standardization of power connectors.

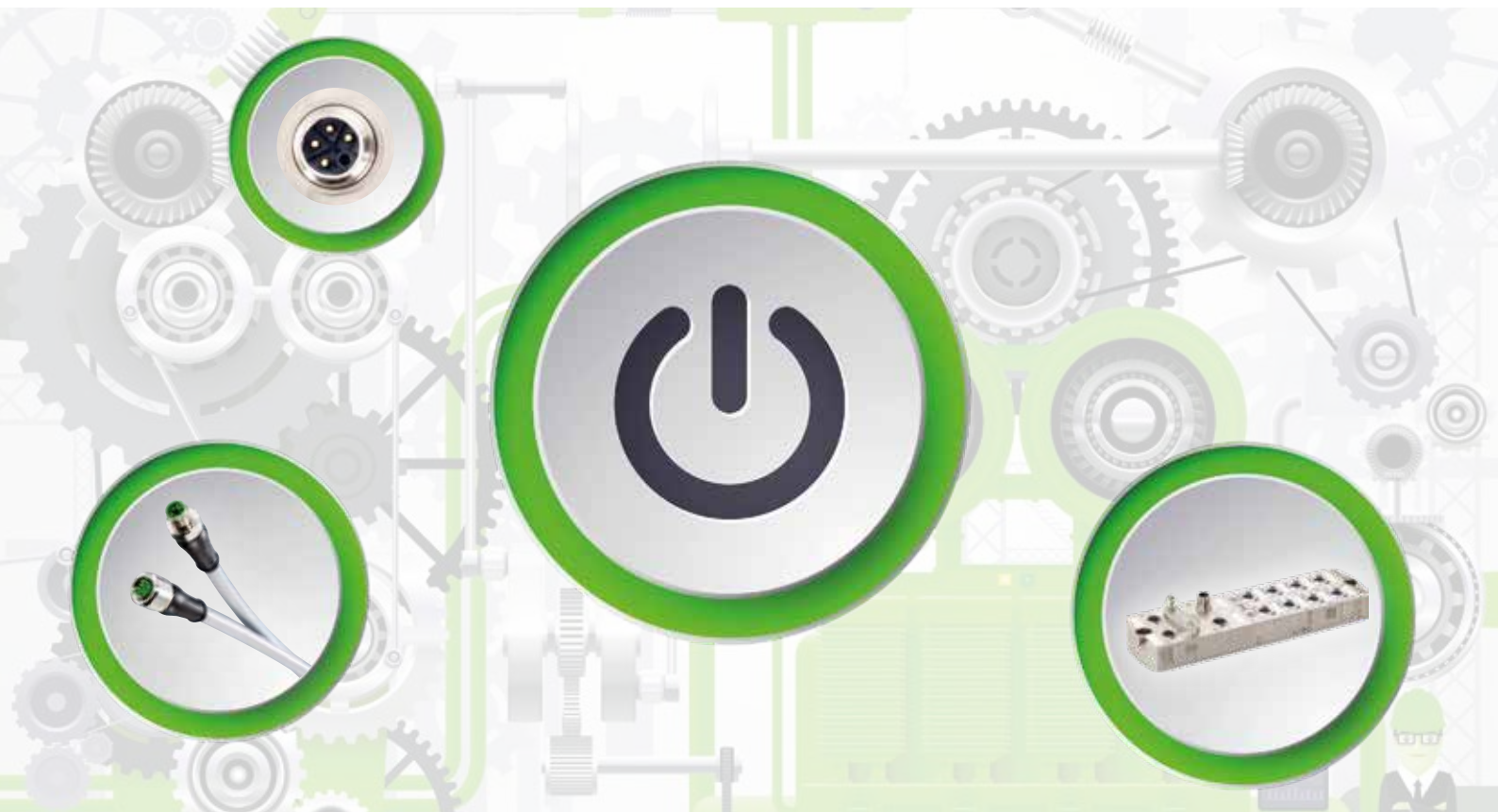

*The new L-coded M12 is the final link in the comprehensive standardization of I/O modules and field equipment.*

# Contents

Digital Transformation needs Standards .....	4
Functional Grounding and Purpose .....	7
PI Guideline for PROFINET Wiring .....	10
Conclusion .....	13
Literature .....	14

## Digital Transformation needs Standards

**The digital transformation requires us to rethink in many areas. Standardization plays a crucial role in this, especially with regard to connection technology.**

Norms and standards define state-of-the-art technology and product requirements, enabling technology transfer and the interoperability of components from different manufacturers. Consequently, they also safeguard investments.

In digitization, the interoperability of various systems and components is essential. A wide variety of devices must not only communicate with each other, but also have to be mechanically connected to each other.

Norms and standards provide users with a guarantee that components from different manufacturers are compatible. They allow users to develop a technology-based, all-in-one concept for their machinery and plant.

### Signal and Data Transfer Standards

International signal and data transfer standards (IEC 61076-2-101 [1] and IEC 61076-2-109 [2]) are long established. They laid the ground for the leading role currently held by the M12 connector for sensors, actuators, fieldbus and network technology.

With regard to Ethernet-enabled I/O fieldbus modules, A and D-coded M12 connectors (Fig. 1) stand out from the crowd. They are, in practice, the standard.

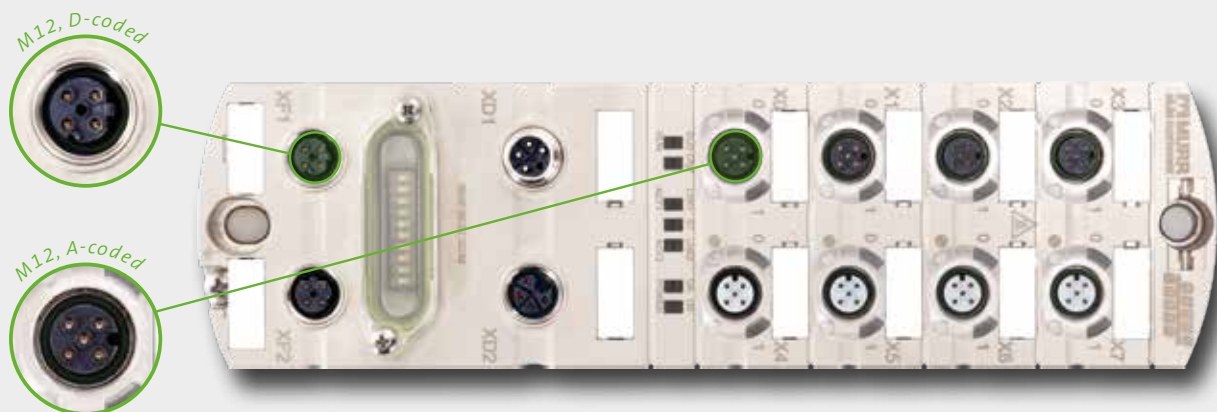

*Fig. 1 Structure of an Ethernet-enabled IP67 rated fieldbus module. On top is a D-coded M12 connector for data transfer (bus protocol) and on the bottom, an A-coded M12 connector for signal transfer (I/O). Both are female connectors.*

## **Standards for Power Transmission / Supply Voltage**

For a long time, there were no standards for power transmission and supply voltage connectors. This resulted in a wide variety of options ranging from M12 A-coded to 7/8" to M23. The market bristled with connector technologies.

While users were soon reassured that they could continue using their existing signal and data connectors (M12 A- and D-coded), this was usually not the case for power connectors. In some cases, products needed to be replaced. Replacement often meant modifying the functional grounding.

As a result, a separate standard was recently issued the IEC 61076-2-111 [3], which defines M12 power connectors.

This standard includes M12 S, L, K and T power coding.

While S- and K-coding are intended for alternating current (AC) applications up to 630V and 12 A, T- and L-coding were developed for direct current (DC) applications up to 63 V and 12 or 16 A.

S-coding has four contacts: three conductors plus PE, short for protective earth.

K-coding offers five contacts: four conductors plus PE.

Compared to T-coding, L-coding consists of four conductors plus an additional contact for functional earth (FE).

## M12 Power L-Coding

L-coding (Fig. 2) is ideal for connecting decentralized field equipment such as I/O fieldbus modules.

This new coding offers almost 80% more power compared to previous 7/8" solutions – transmitting 16 A compared to 9 A. Sizewise, the new solution approximately 30–40% smaller.

The new L-coded M12 connector not only takes a decisive step towards miniaturization, but also represents the final piece needed in the comprehensive standardization of field equipment.

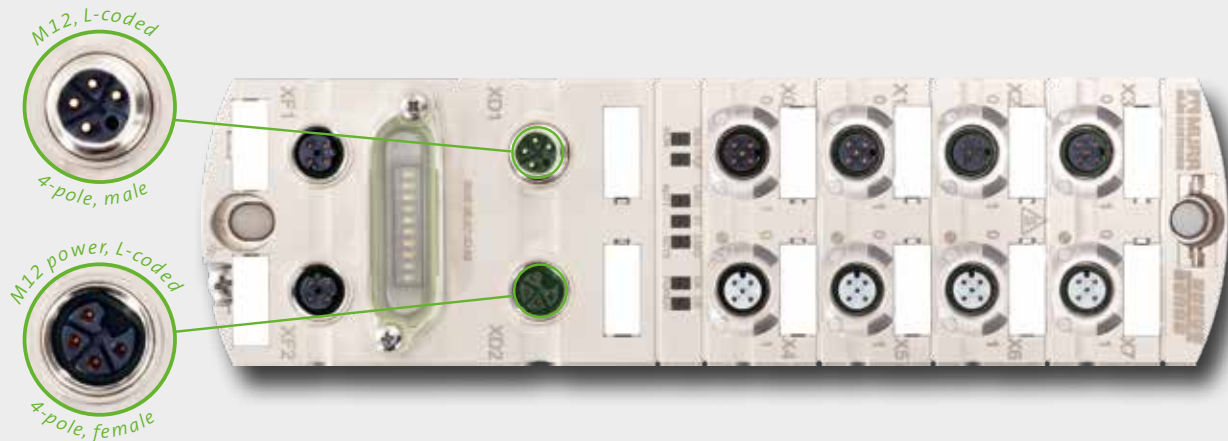

Fig. 2 The L-coded M12 power connector for a fieldbus module. The illustration shows both a male and female connector.

# Functional Grounding and Purpose

**Functional grounding or the FE contact is not only aimed at protection and safety. As its name suggests, it is primarily responsible for the ideal function and the uninterrupted operation of plants, machinery and equipment.**

Functional grounding discharges electromagnetic disturbances from electronic equipment and enhances EMC strength. FE contacts also provide a common reference potential for electrical installations and equipment to minimize interference voltage, ensuring disturbance-free operation.

## Functional Grounding Methods

Functional grounding for field equipment can be set up in various ways. The most common methods employ flat ground straps or grounding via connectors (FE contact). Occasionally, both methods are used together (Fig. 3).

When designing a grounding concept, you need to make sure that electrons with increasing frequencies are not spread over the entire cable cross section. They should flow and be concentrated on the conductor surface. This phenomenon is known as the skin effect. Discharging hinges not on the conductor cross section, but its surface. Fine-wire (flat) ground straps have a larger surface than circular connectors and are therefore better suited for discharging interference.

The specific inductance of connecting cables must also be taken into account. The longer the cable and higher the frequency, the greater the impedance. Inductance is much lower on ground straps compared to connecting cables with the same cross section. As a result, when discharging interference voltages between field equipment and reference ground, a short connection with low impedance is recommended.

Further regulations regarding interference voltages and electromagnetic disturbance values are summarized in IEC 60364-4-44 [5].



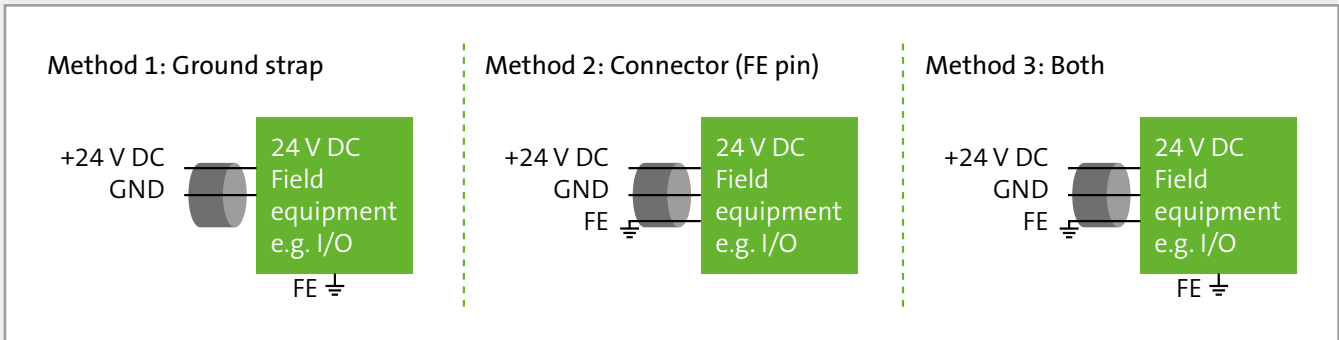

Fig. 3 Various methods of functional grounding for field equipment. Depending on the system used, grounding is possible via a ground strap, connector (FE pin) or both.

### Method 1: Grounding via ground strap

For functional grounding using a ground strap, a special strap is fastened to the device housing at the grounding point (labeled XE or by a functional grounding icon) and the reference ground using a conductive metal screw, washer and serrated washer. In this grounding method, disturbances are discharged directly on the respective device (Fig. 4). This is a very effective solution.

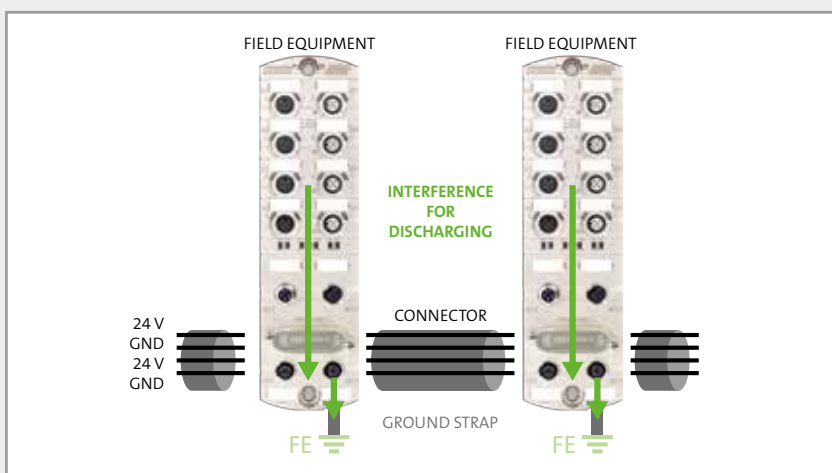

Fig. 4 Method 1: Disturbances are discharged directly on the device with functional grounding via a ground strap.



## Method 2: Grounding via connector

If the system is equipped with a FE contact in both the connector and the field device, direct functional grounding is possible via the connector. This is done by linking the connector to the I/O module or field device. In addition, the FE contact of the first, or extreme left-positioned, connector has to be linked to the reference ground. In this grounding method, interference is looped through the device or, more precisely, its electronics (Fig. 5).

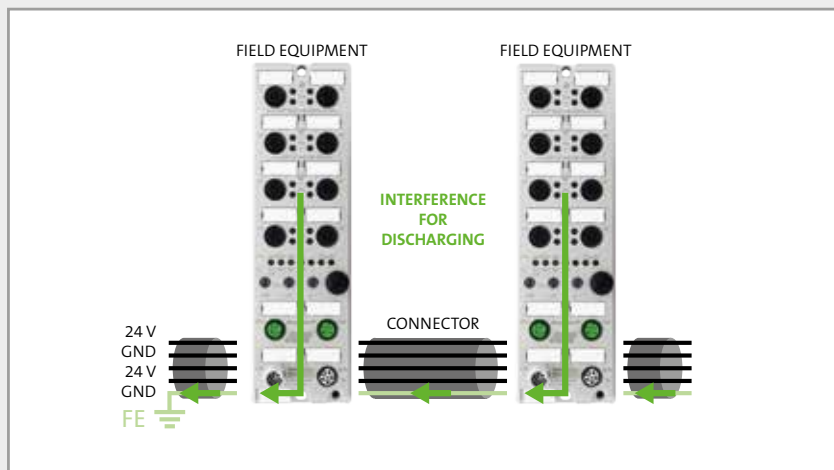

Fig. 5 Method 2: Disturbances are looped through the equipment electronics with functional grounding via a FE contact in the connector.

## Method 3: Grounding via ground strap and connector

Frequently, field equipment with a FE contact is also equipped with an additional ground connection on the housing for attaching a ground strap. An external ground connection is mandatory for PROFINET devices.

Depending on the application, additional functional grounding may have to be done via the ground strap to achieve adequate interference resistance on the device. In the case of double functional grounding, the possibility of further electromagnetic effects occurring, including the formation of inductance loops, must be taken in account.

## PI Guideline for PROFINET Wiring

The "PROFIBUS and PROFINET International" (PI) user organization recognized early on that standard connectors made users' lives easier and therefore defined clear standards for PROFINET systems.

PI sets out these standards in its "PROFINET Cabling and Interconnection Technology" Guideline [4]. The present version (May 2017) includes the new standards for supplying power to field equipment.

In the future all PROFINET field devices will be fitted with the new M12 L-coded connectors as standard instead of power class-dependent equipping with either a M12 A-coded or 7/8" connector.

Mechanically compatible 4- and 5-pole versions have been included in the guideline for this purpose. Aside from four conductors, the 5-pole version also has a functional ground contact.

Color coding was introduced for better identification and to avoid confusion (Fig. 6):

- 4-pole versions usually have a black contact carrier and jacket
- 5-pole versions are gray in both cases.

New M12 L-coded connectors offer a solution for both grounding methods.

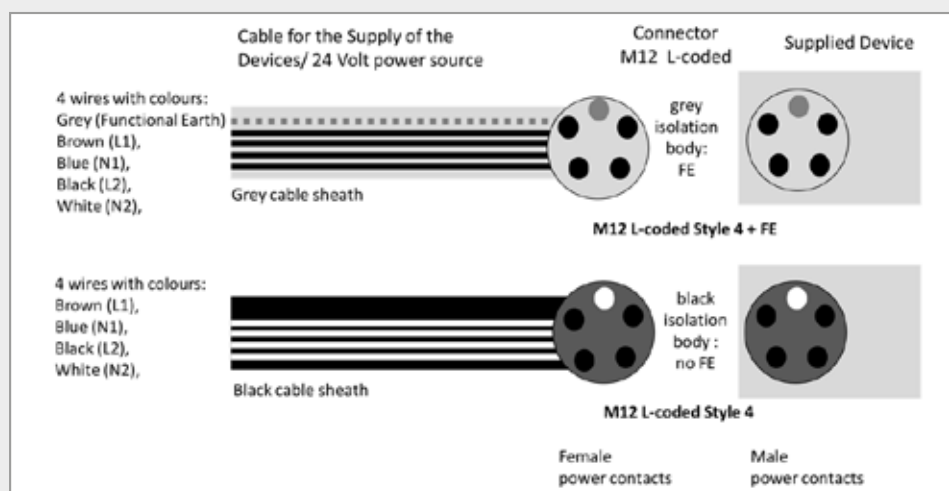

Fig. 6 [4]: Excerpt from "PROFINET Cabling and Interconnection Technology" Guideline for M12 L-coded connectors.

## Migration of Old Systems

Previous performance-based power connectors (in the PROFINET environment) are not compatible with one another due to design differences. As a result, users who needed more power in their system, not only had to replace the I/O modules, but also their power connectors.

Problems like this will cease to exist with the new L-coded system. All future PROFINET devices will be fitted with this connector offering a huge jump in performance.

One-off outlays will still be involved in migrating to a new system. The following approaches are recommended to minimize conversion efforts:

#	Previous power connectors	Recommendation for new systems
1	M12 or 7/8", 4-pole	M12 L-coded, 4-pole
2	M12 or 7/8", 5-pole	M12 L-coded, 5-pole
3	Others	Free choice

## Compatibility within L-Coding

In view of the common type standard and mechanical compatibility of the L-coded connector system, mixing within the L-coding system is possible, as the following table shows:

#	L-coded connector	L-coded field equipment	Functional grounding
1	4-pole	4-pole	Ground strap
2	4-pole	5-pole (4+FE)	Ground strap
3	5-pole (4+FE)	5-pole (4+FE)	Connector (and optionally, also via ground strap)

According to this figure, a 5-pole field device can be used for both 4- and 5-pole L-coded applications, although strictly speaking, this should only be done in exceptional cases.

Depending on how the functional ground is designed, a choice of either the 4- or 5-pole system should be made to avoid installation faults from the outset.

The color coding – gray and black – can be a great help in avoiding and eliminating any confusion during installation.

Combinations other than the ones illustrated here are not recommended, as they might result in faults or the destruction of the field equipment.

## Conclusion

**L-coding for M12 connectors significantly changes connection technology for field equipment. With their 16 A rating, these compact M12 connectors are ideal for use in the field.**

In addition to established international standards for signal and data connection in M12 technology, the M12 Power (L-coded) now also offers a feasible solution for power transmission and supply in the field.

This is the final piece of the puzzle the comprehensive standardization of field equipment. It reduces connector diversity and turns "plug & play" into reality. This not only assures users of component interoperability from different manufacturers, but also safeguards their investments.

The high rating (up to 16 A per pin) lets users make full use of the potential offered by field equipment. With L-coding larger daisy chains can be put together, reducing wiring outlay and shortening installation times. This paves the way to decentralization and zero cabinet.

As a provider of decentralized installation technology solutions, Murrelektronik offers both L-coded M12 power connectors and matching I/O fieldbus modules, power supplies current monitoring systems and an extensive portfolio of accessories (Fig. 7).

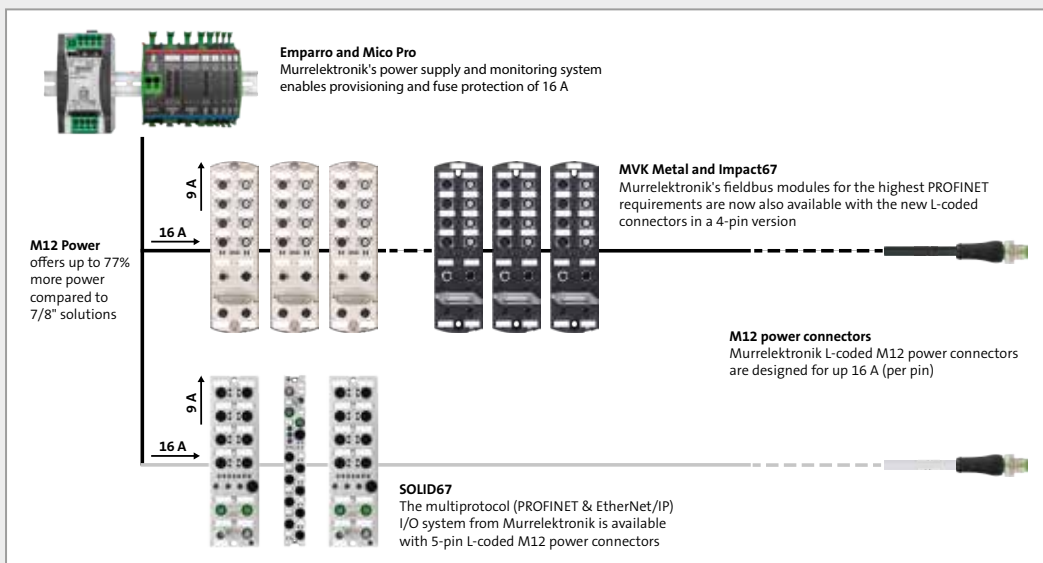

Fig. 7 Fieldbus modules with L-coded M12 power connections add additional power to a system and enable users to link more modules together.

## Literature

- [1] IEC 61076-2-101:2012-04 Connectors for electronic equipment – Product requirements – Part 2-101: Circular connectors – Detail specification for M12 connectors with screw-locking. Bureau Central de la Commission Electrotechnique Internationale, Genf/Schweiz.
- [2] IEC 61076-2-109:2014-04 Connectors for electronic equipment – Product requirements – Part 2-109: Circular connectors – Detail specification for connectors with M 12 x 1 screw-locking, for data transmission frequencies up to 500MHz. Bureau Central de la Commission Electrotechnique Internationale, Genf/Schweiz.
- [3] IEC 61076-2-111:2017-11 Connectors for electrical and electronic equipment – Product requirements – Part 2-111: Circular connectors – Detail specification for power connectors with M12 screw-locking. Bureau Central de la Commission Electrotechnique Internationale, Genf/Schweiz.
- [4] PROFINET Cabling and Interconnection Technology, Version 4.00 – Date May 2017. PROFIBUS & PROFINET International (PI), Karlsruhe/Deutschland.
- [5] IEC 60364-4-44:2007/AMD2:2018 Amendment 2 – Low-voltage electrical installations – Part 4-44: Protection for safety – Protection against voltage disturbances and electromagnetic disturbances. Bureau Central de la Commission Electrotechnique Internationale, Genf/Schweiz.



White paper by

Mail

**Paul.Just@murrelektronik.de**

Web

**Senior Product Manager**

**Phone: +49 (0)7191 47 4212**

**Mobile: +49 (0)174 926 2953**

### **About the author**

Paul Just has been Senior Product Manager at Murrelektronik's headquarters in Oppenweiler (Baden-Württemberg) since November 2018 and is committed to expanding the company's Innovation & Platform Automation division. His track record

includes more than seven years' experience in industrial automation technology, focusing on industrial networks and I/O systems. He has assisted customers and partners with their system integration and has held numerous technology workshops.

### **About Murrelektronik**

Murrelektronik is an international, family-run company in the automation technology sector with more than 2,700 employees. The vision and mission of Murrelektronik is to optimize machinery and plant installations and thus generate a competitive edge for its customers. Decentralization is the company's speciality: the control layer of machinery

and plant is optimally connected to the sensor-actuator layer with proven concepts and innovative technologies. Close customer cooperation is vital to develop customized solutions for optimum machine installation. High product availability rounds off the Murrelektronik portfolio and the customer experience.